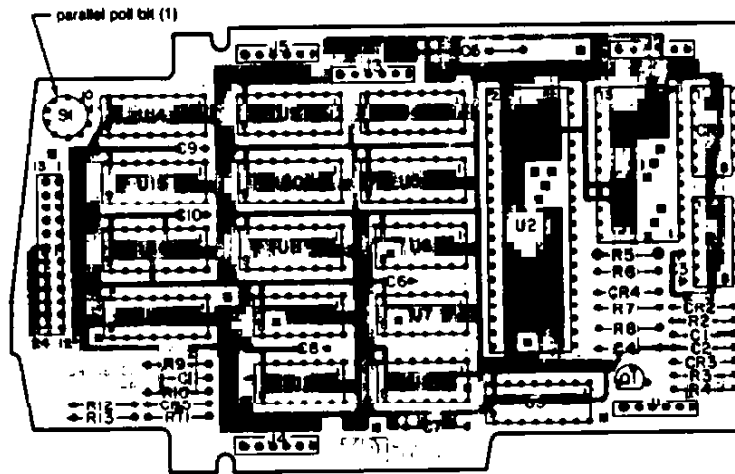

Table 9d. A2/A4 Replaceable Parts

REFERENCE DESIGNATOR	-hp- PART NO.	CHECK DIGIT	TQ	DESCRIPTION
A2	98034-66502	6	1	PC Assembly: HP-IB Control Logic
A4	98034-66504	5	1	PC Assembly: HP-IB Control Logic (98034B)
A2C1,C2	0180-0210	6	2	Cap, Fixed: 3.3 μ F, 15V
A2C3,6,8-10, C12-C14,C16	0160-4571	8	9	Cap, Fixed: 0.1 μ F, 100V
A2C4,C17	0160-3334	9	2	Cap, Fixed: 0.01 μ F, 50V
A2C5	0180-0106	9	1	Cap, Fixed: 60 μ F, 6V
A2C7	0160-3847	9	1	Cap, Fixed: 0.01 μ f, 25V
A2C11	0160-0495	7	1	Cap, Fixed: 390pF, 300V, \pm 1%
A2C15	0121-0180	5	1	Cap, Variable: 15 to 60pF
A2CR2,CR3, CR5	1901-0040	1	3	Diode: Si, 0.05A, 30V
A2CR4	1902-3158	0	1	Diode, Zener: 9.76V, \pm 2% @ 10ma
A2P1-P5	1251-4215	1	5	Connector: 6-pin
A2J1	1251-4333	4	1	Connector: 24-pin
A2Q1	1853-0016	8	1	Transistor: PNP, Si
A2Q2	1854 0071	7	1	Transistor: PNP, Si
A2R2	0683-5615	1	1	Res, Fixed: 560 Ω , 5%, 1/4W
A2R3	0683-3325	6	1	Res, Fixed: 3.3K Ω , 5% 1/4W
A2R4,R9,R12	0683-2225	3	3	Res, Fixed: 2.2K Ω , 5%, 1/4W
A2R5	*		1	(Optimum Value Selected at the factory)
A2R6	0683-1815	5	1	Res, Fixed: 1.8K Ω , 5%, 1/4W
A2R7	0683-2025	1	1	Res, Fixed: 2.0K Ω , 5%, 1/4W
A2R8	0683-5625	3	1	Res, Fixed: 5.6K Ω , 5%, 1/4W
A2R10	0698-3225	6	1	Res, Fixed: 1.43K Ω , 1%, 1/8W
A2R11	0698-3557	7	1	Res, Fixed: 806 Ω , 1%, 1/8W
A2R13	0683-1035	1	1	Res, Fixed: 10K Ω , 5%, 1/4W
A2R14	0683-1515	3	1	Res, Fixed: 150 Ω , 5%, 1/8W
A2R15	0693-1515	3	1	Res, Fixed: 150 Ω , 5%, 1/4W
A2SW1	3100-3378	8	1	Switch, 1P10T: Parallel Poll Bit
A2U1	1816-1242	6	1	IC: PROM
A2U2	1820-1692	9	1	IC: Nanoprocessor
etch A2U3	1820-1216	3	1	IC: SN74LS138N, Decoder
A2U4,U5	1820-1562	2	2	IC: MM74C175N, 4-bit Register
A2U6	1820-1112	8	1	IC: SN74LS74, Dual Flip-flop
A2U7	1820-1201	6	1	IC: SN74LS08N, Quad And Gate
A2U8	1820-1199	1	1	IC: 74LS04N, Hex Inverter
A2U9,U10	1820-1439	2	2	IC: SN74LS258N, Quad Data Selector
A2U11	1820-1192	4	1	IC: SN74LS175, Quad D Flip-flop
A2U12	1820-1417	6	1	IC: 74LS26N, Quad HV NAND Gate
A2U13	1820-1425	6	1	IC: SN74LS132N, Quad NAND Schmitt
A2U14,U17	1820-1689	4	1	IC: MC3446P, HP-IB Bus Buffer
A2U18	1810-0326	3	1	Resistor/Diode Network



**COMPONENT SIDE
A2**

HP Part No. 08034-66502 Rev B

When replacing the nanoprocessor chip (P/N 1820-1692) be sure to provide the correct value for A2R5. This resistor determines the amount of back-bias voltage that the nanoprocessor receives. The correct value for back-bias voltage is printed on the nanoprocessor chip and will vary from approximately -2.0 volts to -5.0 volts. The following table provides the part numbers and resistor values to be used to provide the correct voltage.

Table 9e. Replacement Values for A2R5

BACK-BIAS VOLTAGE	RESISTOR VALUE	A2R5 PART NUMBER	CHECK DIGIT
-2.0V	365Ω	0757-0412	3
-2.5V	475Ω	0757-0415	6
-3.0V	604Ω	0757-0161	9
-3.5V	750Ω	0757-0420	3
-4.0V	909Ω	0757-0422	5
-4.5V	1100Ω	0757-0424	7
-5.0V	1300Ω	0757-0426	9

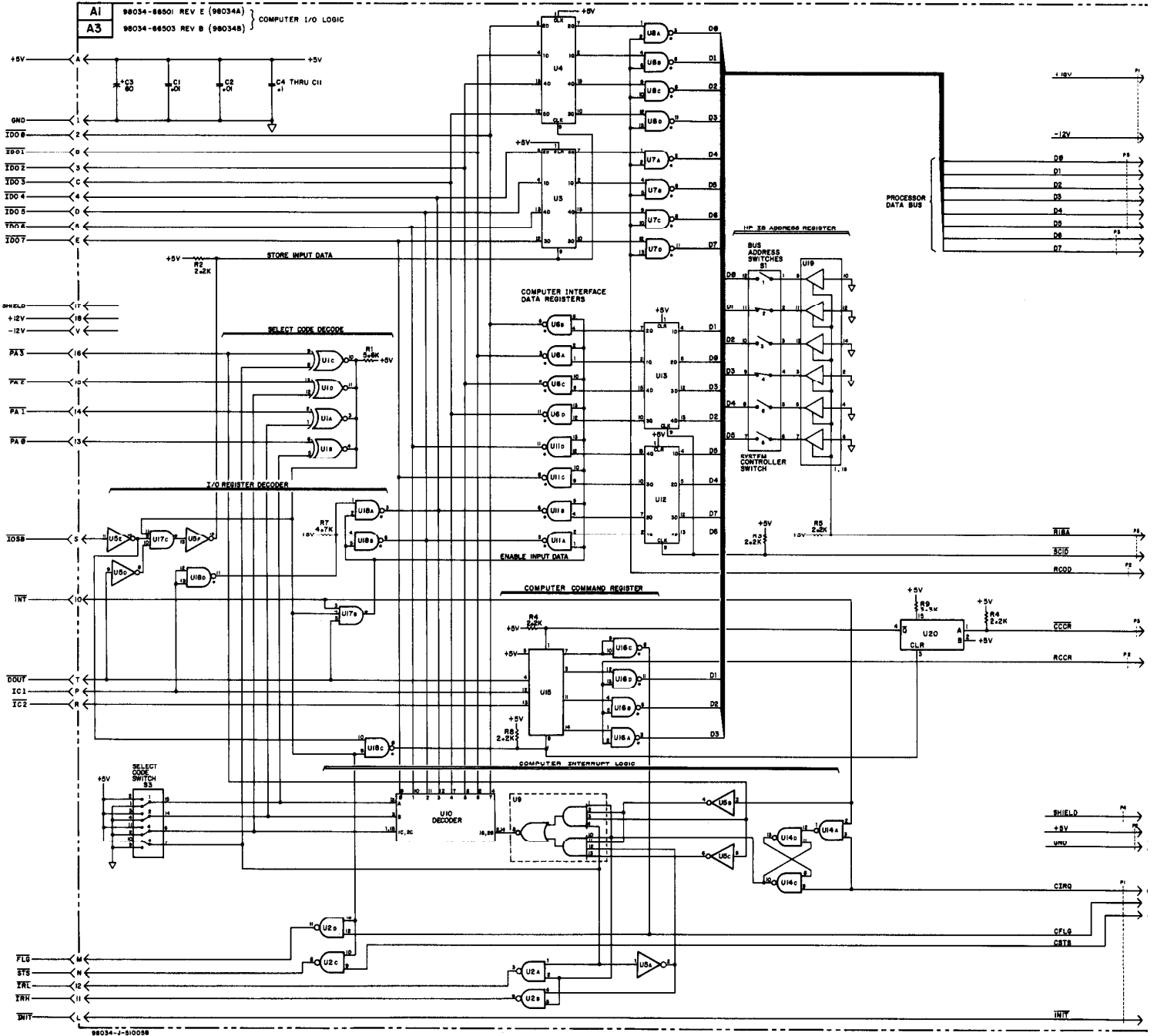

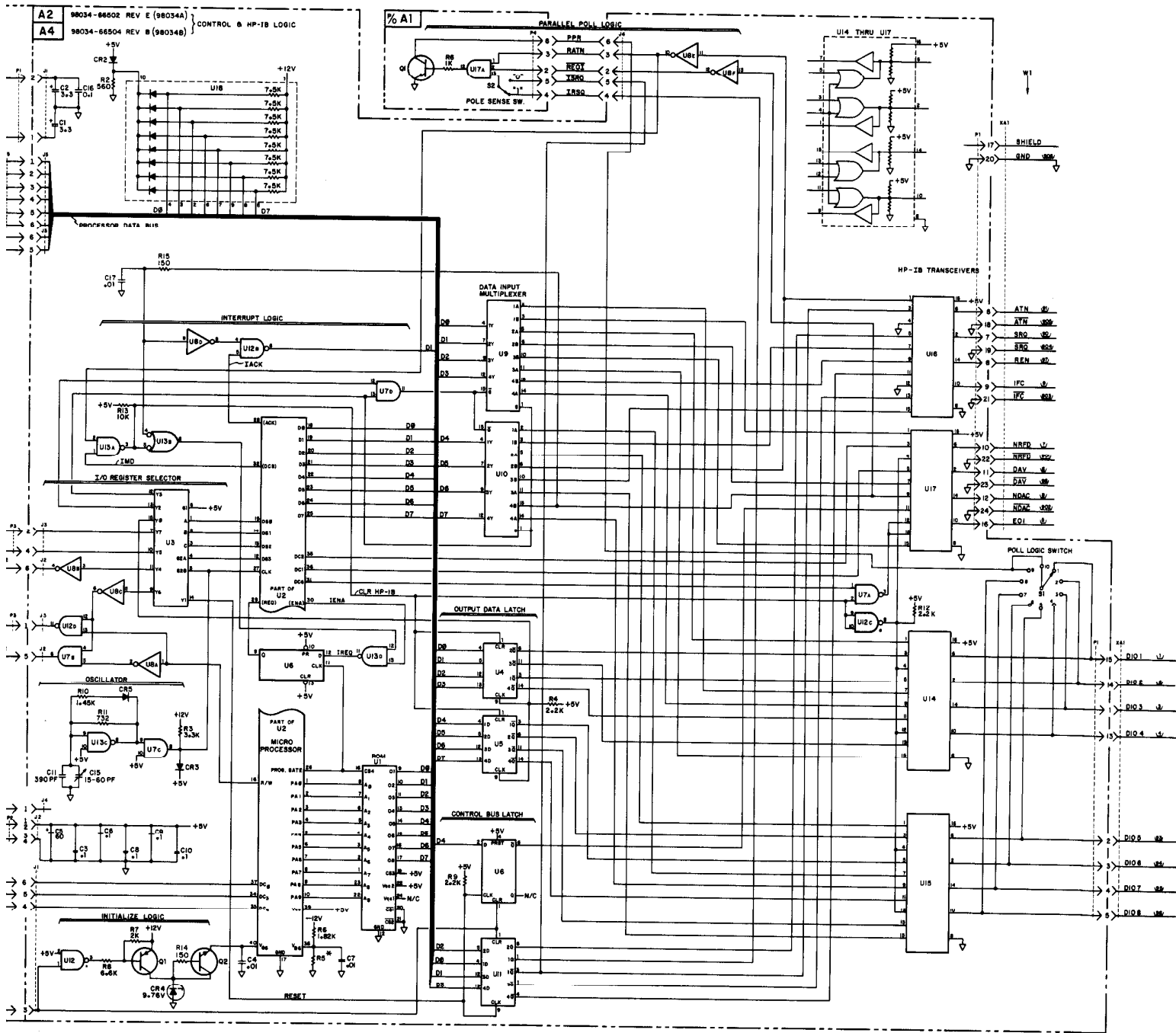

Figure 10. 98034 Circuit Diagram